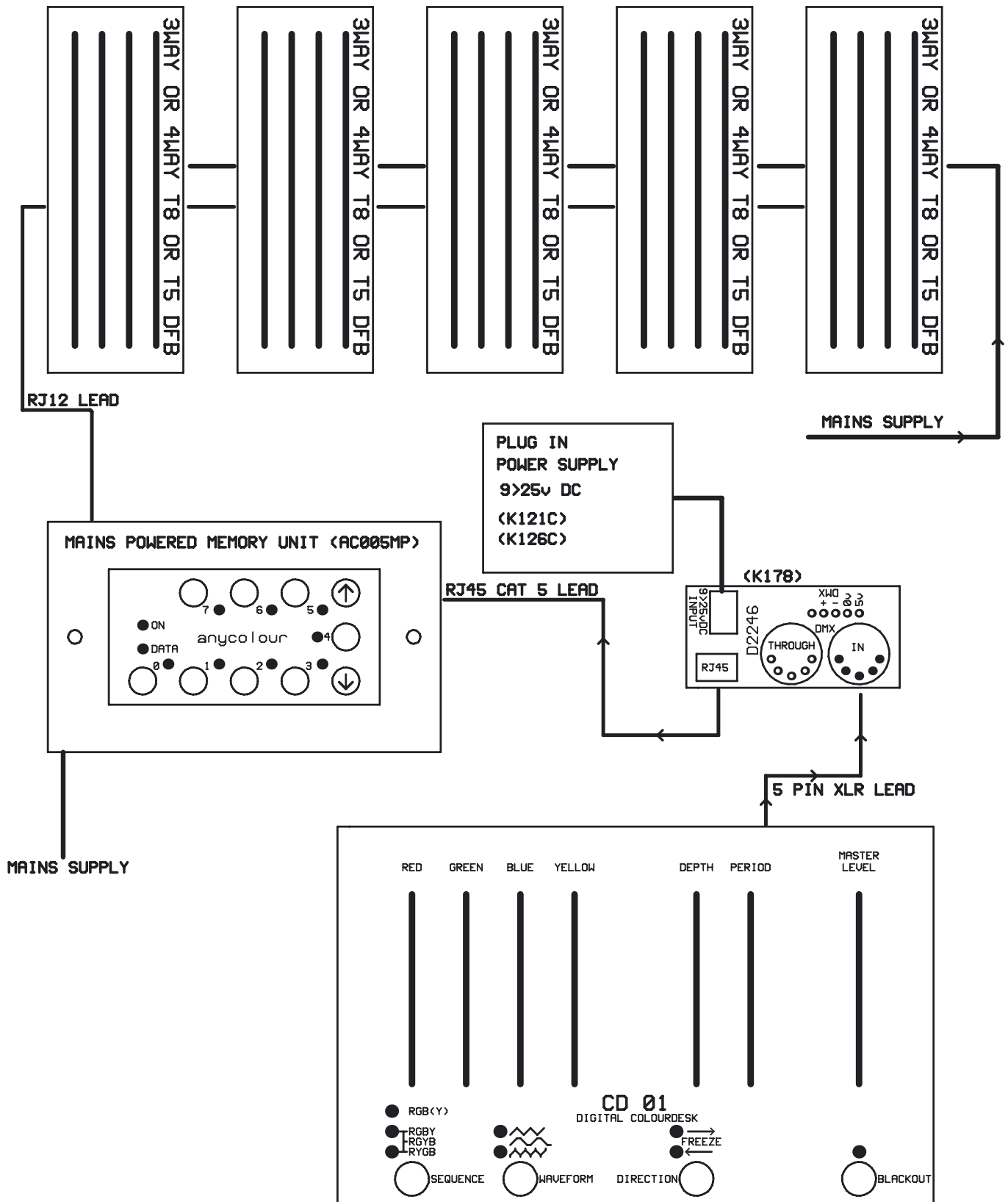

**DIAGRAM 4= CONNECTION SYSTEM FOR RE-PROGRAMMING A MAINS POWERED MEMORY UNIT.**



WHEN PROGRAMMING A MAINS POWERED MEMORY UNIT FROM A CD01 PLEASE CONNECT IN THE FOLLOWING WAY.

- 1: ISOLATE THE MEMORY UNIT FROM THE MAINS SUPPLY.
- 2: CONNECT THE CD01 TO THE MEMORY UNIT IN THE MANNER SHOWN USING PCB (PART No K178) AND DC POWER SUPPLY. REMOVE THE RJ12 LEAD FROM THE MEMORY UNIT AND PLUG IT IN TO THE CD01, THIS ENABLES YOU TO SEE WHAT YOU ARE PROGRAMMING.
- 3: PROGRAMME AS DESCRIBED IN THE OPERATING INSTRUCTIONS
- 4: WHEN THE PROGRAMMING IS COMPLETE, REMOVE THE DC SUPPLY, CIRCUIT BOARD, CD01 AND ALL LEADS.
- 5: RECONNECT THE RJ12 LEAD AND THE MAINS SUPPLY TO MEMORY UNIT.